

8.3 KE Series

Model Number for KE030

KE030	-1	C	-300	A	F0	S1	M
Model	Lead	Precision Grade	Effective Stroke	Slider Type	Motor Flange	Limit Switch	Motor
	1 mm	C: Normal P: Precision		A: Standard	F0 : Direct	S1: OMRON SX671 S2: OMRON SX674 S3: Panasonic GX-F12A S4: Panasonic GX-F12A-P None: No Limit Switch	M:customer specified None:Without Motor

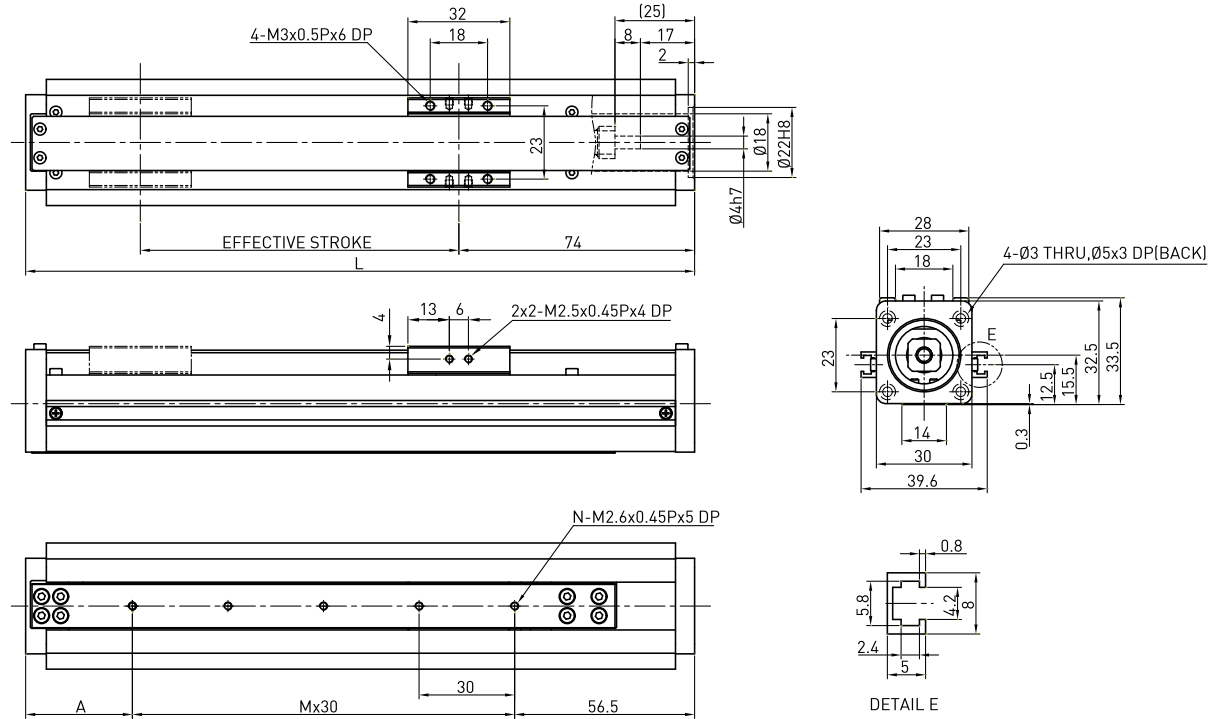

Effective stroke (mm)	L	A	M	N	Weight (kg)	AC motor output	W	28 stepping motor	
50	160	43.5	2	3	0.2	Rated RPM	RPM	-	
100	210	33.5	4	5	0.5	Lead	mm	1.25	
150	260	23.5	6	7	0.8	Max linear speed	mm/sec	62.5	
200	310	43.5	7	8	1.1	Rated thrust	N	175	
250	360	33.5	9	10	1.4	Repeatability	mm	±0.02	
300	410	53.5	10	11	1.9	Effective stroke	mm	50-300	
						Max load (H)	kg	3	
							Fyd	N	4
					Fzd		N	30	
					Mxd		N-m	0.2	
					Myd		N-m	0.1	
					Mzd		N-m	0.1	
						Rated dynamic load*			
						Permitted load condition**	$\frac{F_y}{F_{yd}} + \frac{F_z}{F_{zd}} + \frac{M_x}{M_{xd}} + \frac{M_y}{M_{yd}} + \frac{M_z}{M_{zd}} \leq 1$ Fy, Fz, Mx, My, Mz are working loads		

* The load condition is based on 10,000km operation.

** If used on the vertical axis or in a special condition, please contact HIWIN.

Model Number for KE040

KE040	-10	C	-300	A	F0	S1	M051
Model	Lead	Precision Grade	Effective Stroke	Slider Type	Motor Flange	Limit Switch	Motor
	2 mm 5 mm	C: Normal P: Precision		A: Standard	F0 : Direct	S1: OMRON SX671 S2: OMRON SX674 S3: Panasonic GX-F12A S4: Panasonic GX-F12A-P None: No Limit Switch	M05□, K05□ M10□, K10□ Motor specification: ref. catalof P.167 M:customer specified None:Without Motor

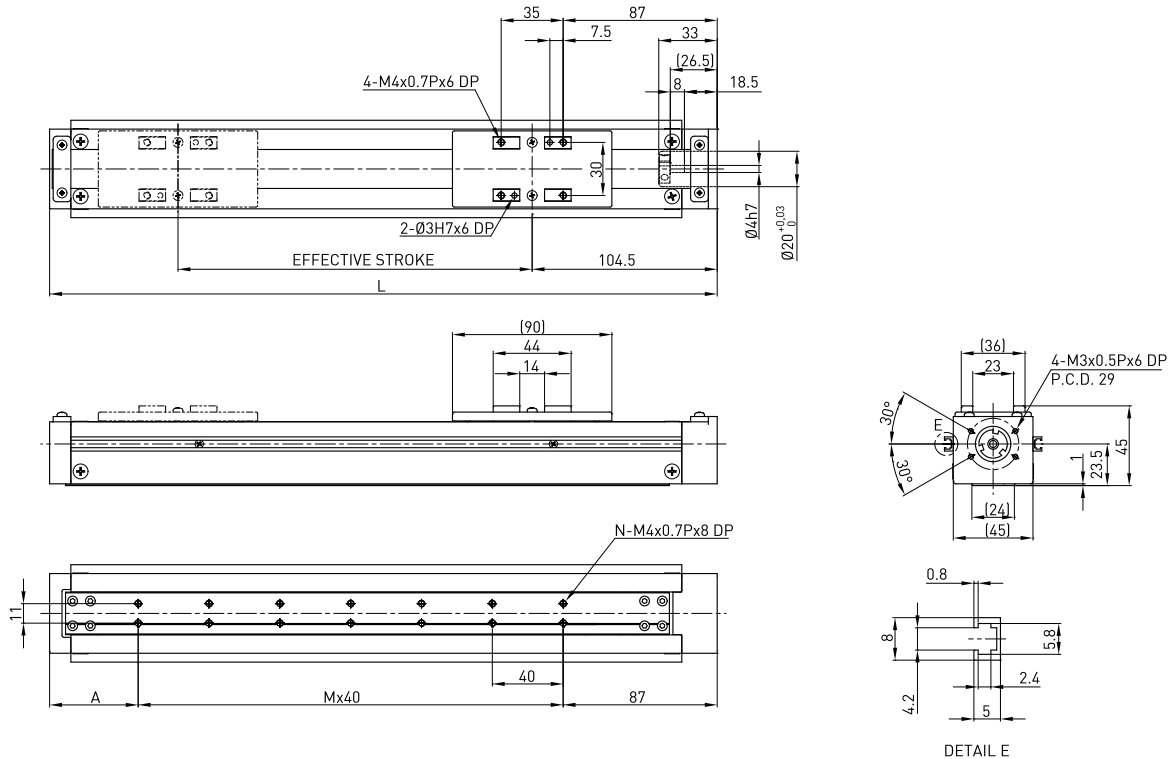

Effective stroke (mm)	L	A	M	N	Weight (kg)	AC motor output	W	50				
						Rated RPM	RPM	3000	3000			
						Lead	mm	2	5			
	50	227	60	2		6	1	Max linear speed	mm/sec	100	250	
	100	277	70	3		8	1.3	Rated thrust	N	280	140	
	150	327	40	5		12	1.6	Repeatability	mm	±0.02		
	200	377	50	6		14	1.9	Effective stroke	mm	50-300		
	250	427	60	7		16	2.2	Max load (H)	kg	6	4	
	300	477	70	8		18	2.5		Fyd	N	10	10
									Fzd	N	60	30
						Mxd	N-m		1	1		
						Myd	N-m	0.55	0.6			
						Mzd	N-m	0.55	0.5			
						Rated dynamic load*						
						Permitted load condition**	$\frac{F_y}{F_{yd}} + \frac{F_z}{F_{zd}} + \frac{M_x}{M_{xd}} + \frac{M_y}{M_{yd}} + \frac{M_z}{M_{zd}} \leq 1$ Fy, Fz, Mx, My, Mz Mz are working loads					

* The load condition is based on 10,000km operation.

** If used on the vertical axis or in a special condition, please contact HIWIN.

Model Number for KE050 (Single Slider)

KE050	-04	C	-400	A	F0	S2	M051
Model	Lead	Precision Grade	Effective Stroke	Slider Type	Motor Flange	Limit Switch	Motor
	4 mm	C: Normal		A: Standard	F0:Direct	S1: OMRON SX671 S2: OMRON SX674 S3: Panasonic GX-F12A S4: Panasonic GX-F12A-P None: No Limit Switch	M05□, K05□ M10□, K10□ Motor specification: ref. catalog P.167 M:customer specified None:Without Motor

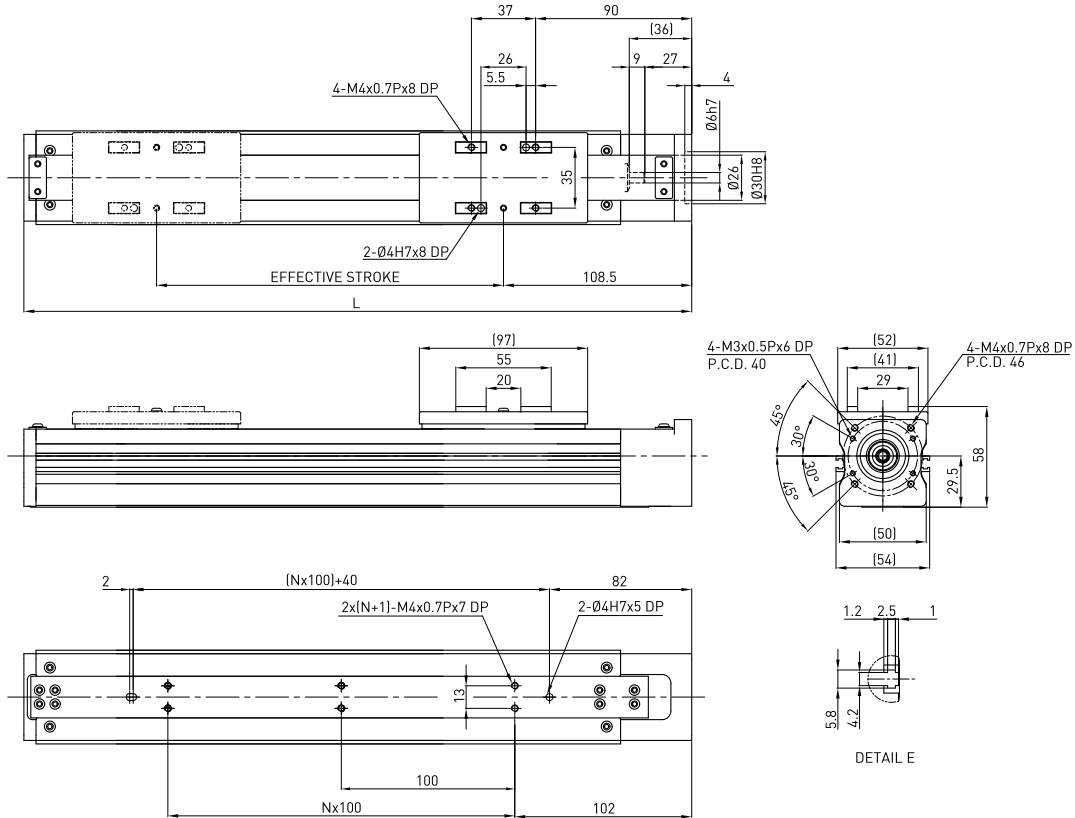

Effective stroke (mm)	L	N	Weight (kg)	AC motor output	W	50	
100	285	1	1.4	Rated RPM	RPM	3000	
200	385	2	1.7	Lead	mm	4	
300	485	3	2	Max linear speed	mm/sec	200	
400	585	4	2.3	Rated thrust	N	175	
				Repeatability	mm	±0.02	
				Effective stroke	mm	100~400	
				Max load (H)	kg	8	
					Fyd	N	10
					Fzd	N	80
					Mxd	N-m	1.5
					Myd	N-m	0.8
					Mzd	N-m	0.8
				Permitted load condition**	$\frac{F_y}{F_{yd}} + \frac{F_z}{F_{zd}} + \frac{M_x}{M_{xd}} + \frac{M_y}{M_{yd}} + \frac{M_z}{M_{zd}} \leq 1$ Fy, Fz, Mx, My, Mz are working loads		

* The load condition is based on 10,000km operation.

** If used on the vertical axis or in a special condition, please contact HIWIN.

Model Number for KE050 (Double Slider)

KE050	D	-04	C	-250	A	F0	S2	M051
Model	Double Slider	Lead	Precision Grade	Effective Stroke	Slider Type	Motor Flange	Limit Switch	Motor
		4mm	C: Normal		A: Standard	F0 :Direct	S2: OMRON SX674 None: No Limit Switch	M05□, K05□ M10□, K10□ Motor specification: ref. catalog P.167 M:customer specified None:Without Motor

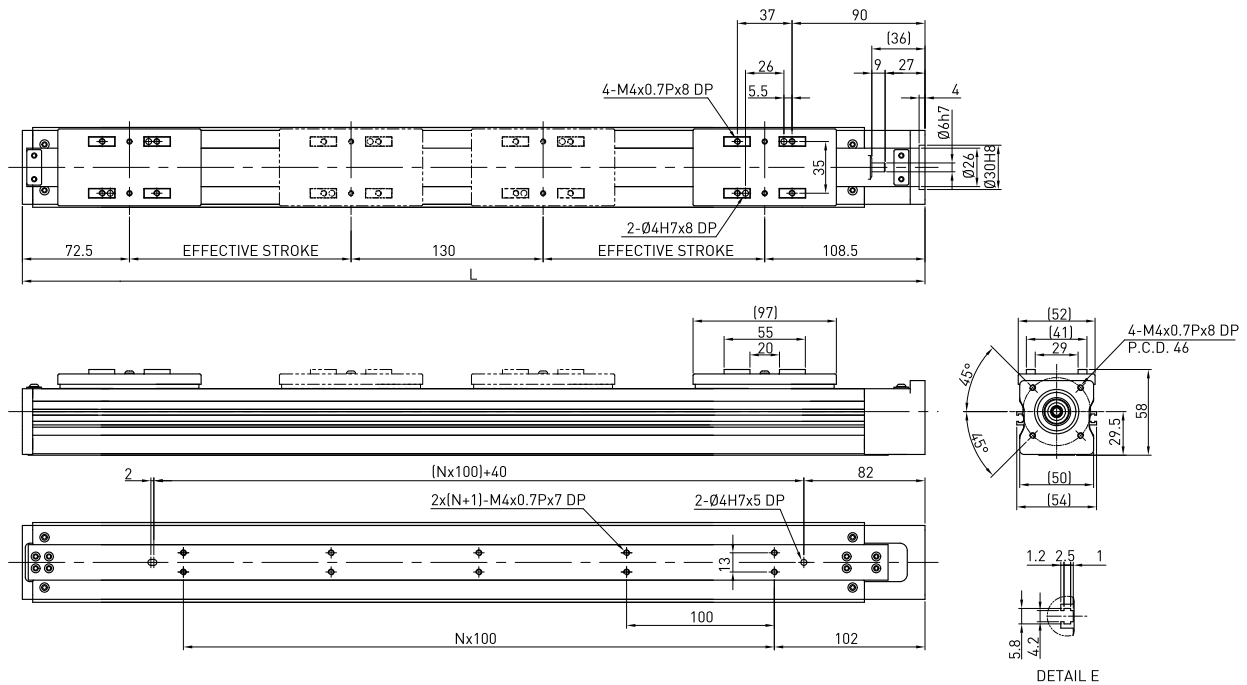

Effective stroke (mm)	L	N	Weight (kg)	AC motor output	W	50	
100	511	3	2.3	Rated RPM	RPM	3000	
150	611	4	2.5	Lead	mm	4	
200	711	5	2.8	Max linear speed	mm/sec	200	
250	811	6	3.0	Rated thrust	N	175	
				Repeatability	mm	±0.02	
				Effective stroke	mm	100~400	
				Max load (H)	kg	8	
					Fyd	N	10
					Fzd	N	80
					Mxd	N-m	1.5
					Myd	N-m	0.8
					Mzd	N-m	0.8
				Permitted load condition**	$\frac{F_y}{F_{yd}} + \frac{F_z}{F_{zd}} + \frac{M_x}{M_{xd}} + \frac{M_y}{M_{yd}} + \frac{M_z}{M_{zd}} \leq 1$ Fy, Fz, Mx, My, Mz are working loads		

* The load condition is based on 10,000km operation.

** If used on the vertical axis or in a special condition, please contact HIWIN.

Model Number for KE065

KE065	-10	C	-600	A	F0	S1	M101
Model	Lead	Accuracy Grade	Effective Stroke	Slider Type	Flange F0	Limit Switch	Motor
	5 mm 10 mm	C: Normal P: Precision		A: Standard	F0: 100W	S1: OMRON SX671 S2: OMRON SX674 S3: Panasonic GX-F12A S4: Panasonic GX-F12A-P None: No Limit Switch	M05□, K05□ M10□, K10□ Motor specification: ref. catalof P.167 M:customer specified None:Without Motor

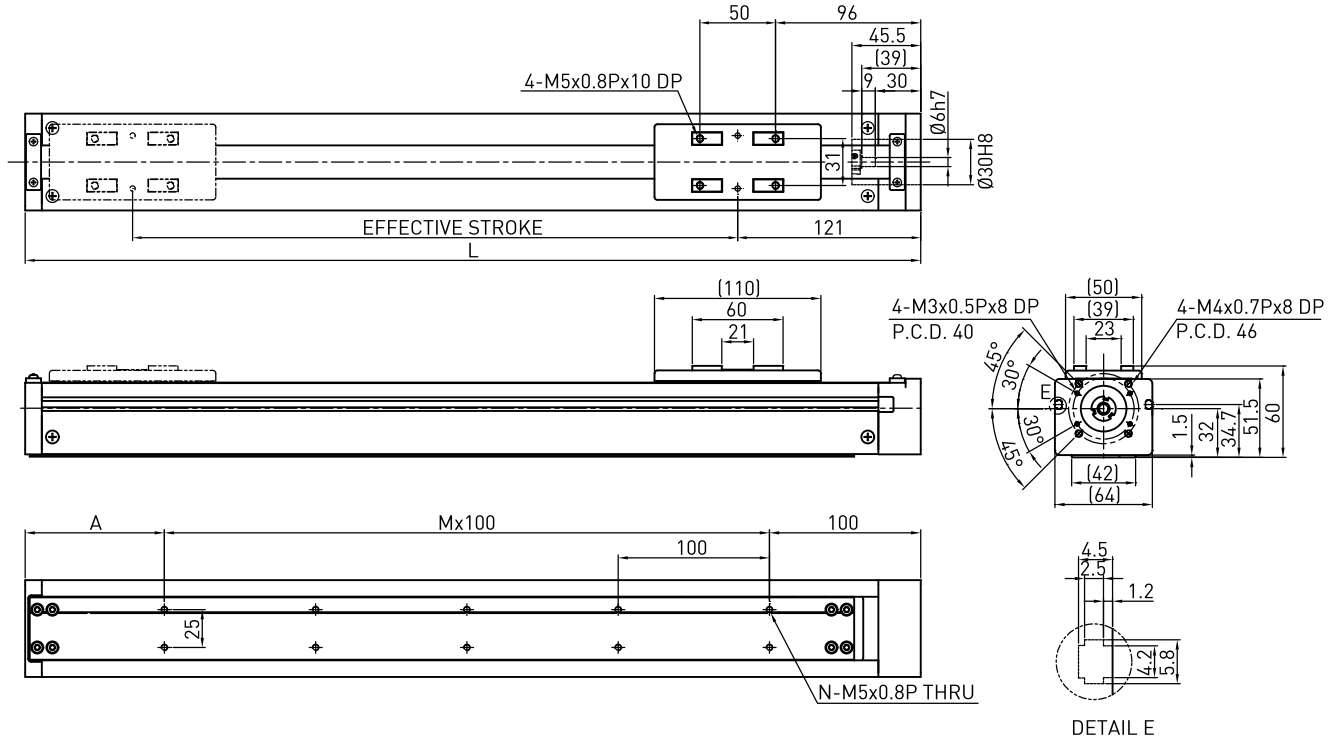

Effective stroke (mm)	L	A	M	N	Weight (kg)	AC motor output	W	100
						Rated RPM	RPM	3000 3000
						Lead	mm	5 10
						Max linear speed*	mm/sec	250 500
						Rated thrust	N	280 140
						Repeatability	mm	±0.02
						Effective stroke	mm	50~600
						Max load (H)	kg	15 8
							Fyd	N 10 10
					Fzd		N 150 80	
					Mxd		N-m 4.4 4.7	
					Myd		N-m 2.3 2.6	
					Mzd		N-m 2.3 2.6	
						Permitted load condition***	$\frac{F_y}{F_{yd}} + \frac{F_z}{F_{zd}} + \frac{M_x}{M_{xd}} + \frac{M_y}{M_{yd}} + \frac{M_z}{M_{zd}} \leq 1$ Fy, Fz, Mx, My, Mz are working loads	

* Vibration might occur when the effective stroke is longer than 550mm.

The maximum speed should be decreased by 15% for every 100mm of increased stroke.

**The load condition is based on 10,000km operation.

***If used on vertical axis or special condition , please contact HIWIN.

Model Number for KE070

KE070	-10	C	-600	A	F0	S1	M101
Model	Lead	Accuracy Grade	Effective Stroke	Slider Type	Flange F0	Limit Switch	Motor
	5 mm 10 mm	C: Normal P: Precision		A: Standard	F0: Direct	S1: OMRON SX671 S2: OMRON SX674 S3: Panasonic GX-F12A S4: Panasonic GX-F12A-P None: No Limit Switch	M05□, K05□ M10□, K10□ Motor specification: ref. catalog P.167 M:customer specified None:Without Motor

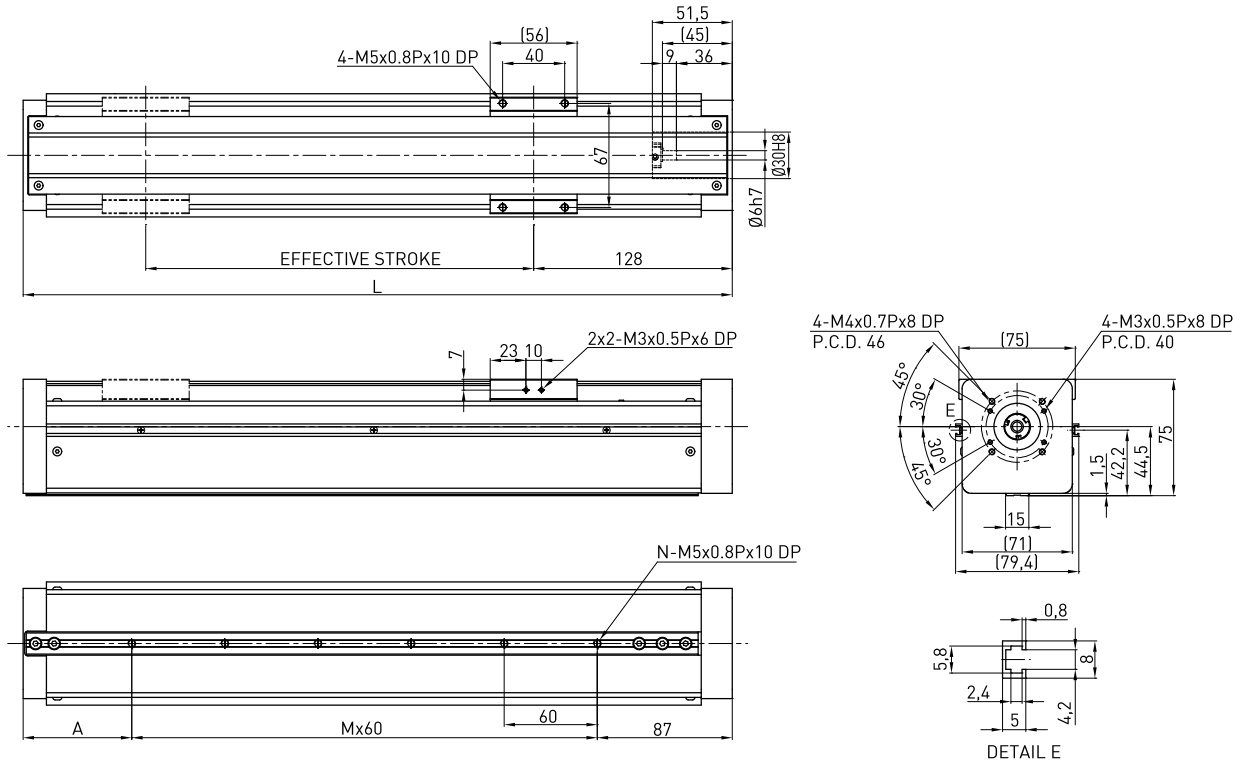

Effective stroke (mm)	L	A	M	N	Weight (kg)	AC motor output		W	100	
						Rated RPM		RPM	3000	3000
50	257	50	2	3	2.8	Lead	mm	5	10	
100	307	40	3	4	3.1	Max linear speed*	mm/sec	250	500	
150	357	90	3	4	3.4	Rated thrust	N	280	140	
200	407	80	4	5	3.7	Repeatability	mm	±0.02		
250	457	70	5	6	4	Effective stroke	mm	50-600		
300	507	60	6	7	4.3	Max load (H)	kg	20	15	
350	557	50	7	8	4.6	Rated dynamic load**	F _{yd}	N	10	10
400	607	40	8	9	4.9		F _{zd}	N	200	150
450	657	90	8	9	5.2		M _{xd}	N-m	3.5	3.5
500	707	80	9	10	5.5		M _{yd}	N-m	2	2.1
550	757	70	10	11	5.8		M _{zd}	N-m	2	2.1
600	807	60	11	12	6.1	Permitted load condition***	$\frac{F_y}{F_{yd}} + \frac{F_z}{F_{zd}} + \frac{M_x}{M_{xd}} + \frac{M_y}{M_{yd}} + \frac{M_z}{M_{zd}} \leq 1$			
							F _y , F _z , M _x , M _y , M _z are working loads			

* Vibration might occur when the effective stroke is longer than 550mm.
The maximum speed should be decreased by 15% for every 100mm of increased stroke.
**The load condition is based on 10,000km operation.
***If used on vertical axis or special condition , please contact HIWIN.

Model Number for KE090

KE090	-10	C	-600	A	F0	S1	M201
Model	Lead	Accuracy Grade	Effective Stroke	Slider Type	Flange F0	Limit Switch	Motor
	5 mm 10 mm	C: Normal P: Precision		A: Standard	F0: Direct	S1: OMRON SX671 S2: OMRON SX674 S3: Panasonic GX-F12A S4: Panasonic GX-F12A-P None: No Limit Switch	M20□, K20□ M40□, K40□ Motor specification: ref. catalof P.167 M:customer specified None:Without Motor

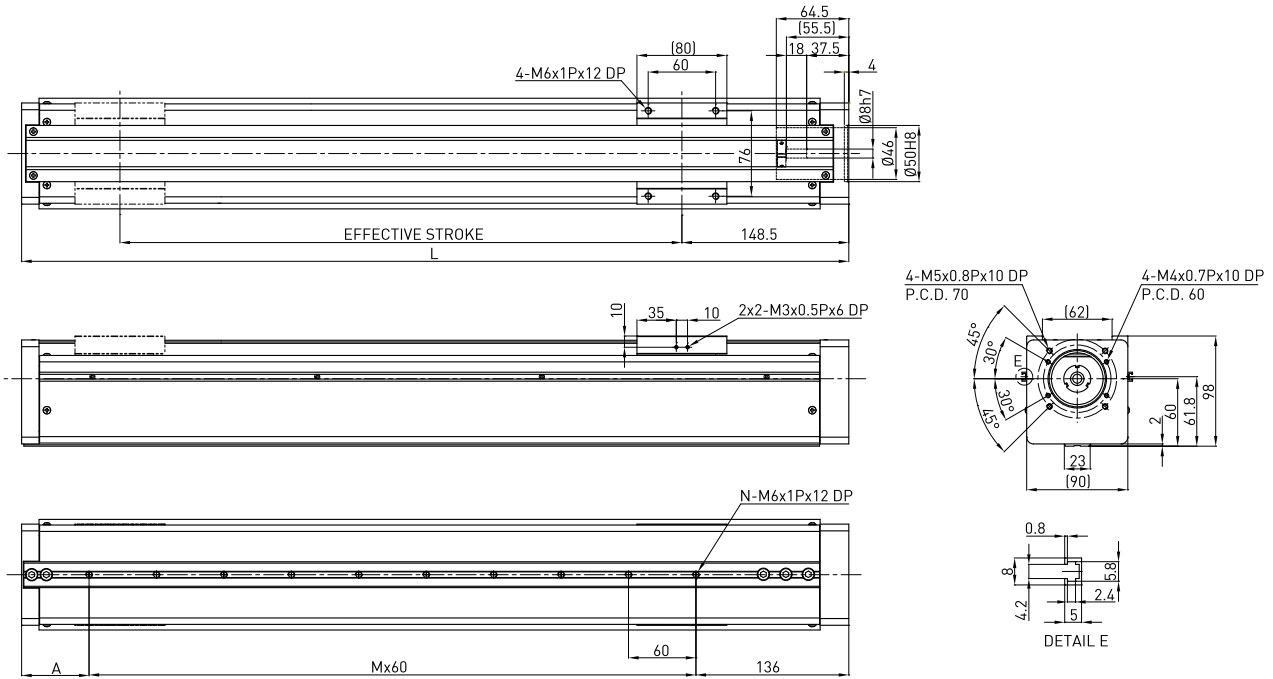

Effective stroke (mm)	L	A	M	N	Weight (kg)	AC motor output	W	200
50	286	90	1	2	6.7	Rated RPM	RPM	3000 3000
100	336	80	2	3	7	Lead	mm	5 10
150	386	70	3	4	7.3	Max linear speed	mm/sec	250 500
200	436	60	4	5	7.6	Rated thrust	N	560 280
250	486	50	5	6	7.9	Repeatability	mm	±0.02
300	536	40	6	7	8.2	Effective stroke	mm	50-600
350	586	90	6	7	8.5	Max load (H)	kg	25 23
400	636	80	7	8	8.8	Rated dynamic load*	Fyd	N 10 10
450	686	70	8	9	9.1		Fzd	N 250 230
500	736	60	9	10	9.4		Mxd	N-m 13 12
550	786	50	10	11	9.7		Myd	N-m 7.1 7.3
600	836	40	11	12	10		Mzd	N-m 7.1 7.3
						Permitted load condition**	$\frac{F_y}{F_{yd}} + \frac{F_z}{F_{zd}} + \frac{M_x}{M_{xd}} + \frac{M_y}{M_{yd}} + \frac{M_z}{M_{zd}} \leq 1$ Fy, Fz, Mx, My, Mz Mz are working loads	

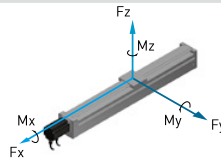

*The load condition is based on 10,000km operation.

**If used on vertical axis or special condition, please contact HIWIN.

8.4 Motor Adaptor Flange List

KE30

Motor Adaptor Flange F0

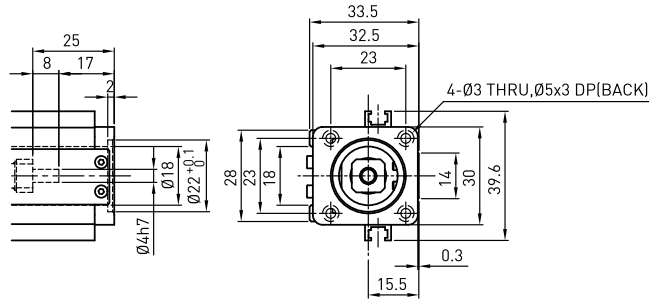

KE50

Motor Adaptor Flange F0

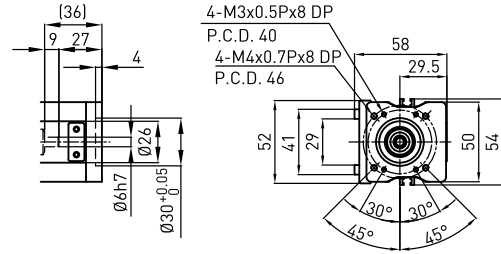

KE40

Motor Adaptor Flange F0

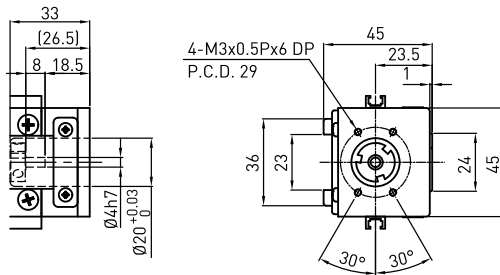

Motor Adaptor Flange F1

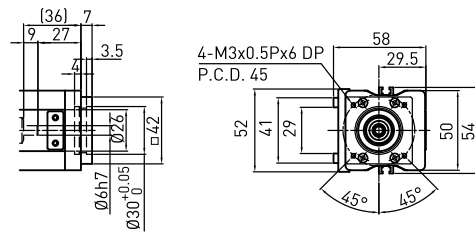

Motor Adaptor Flange F1

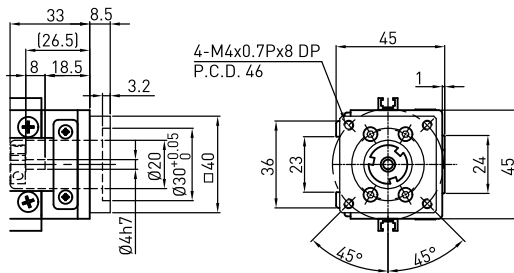

KE65

Motor Adaptor Flange F0

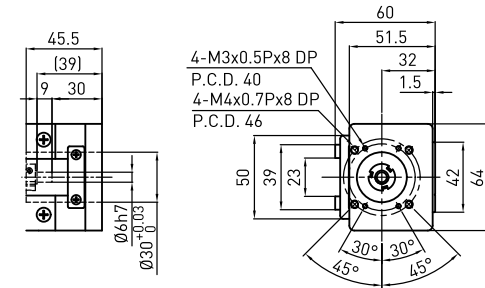

Motor Adaptor Flange F2

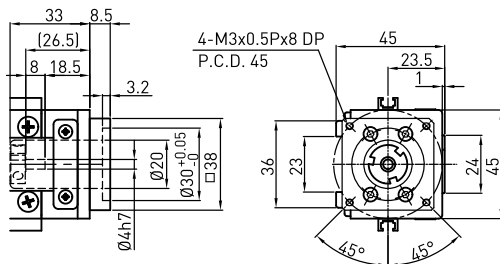

Motor Adaptor Flange F1

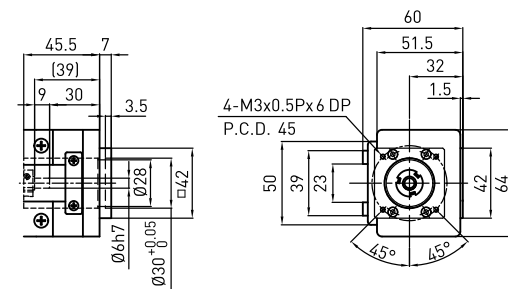

KE70

Motor Adaptor Flange F0

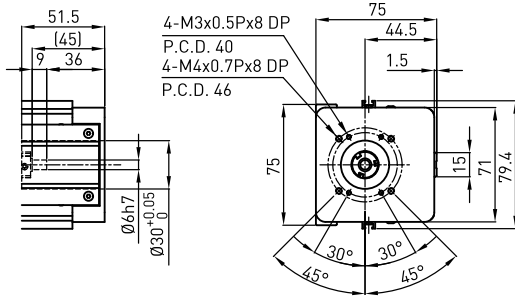

Motor Adaptor Flange F1

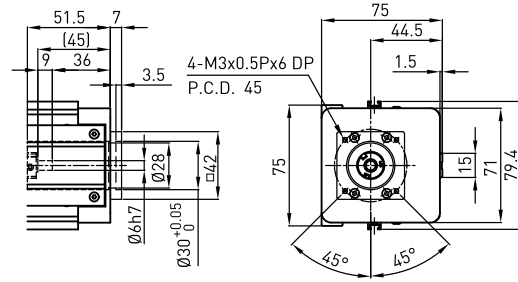

KE90

Motor Adaptor Flange F0

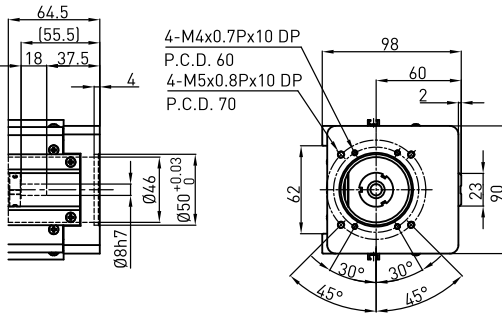

Motor Adaptor Flange F3

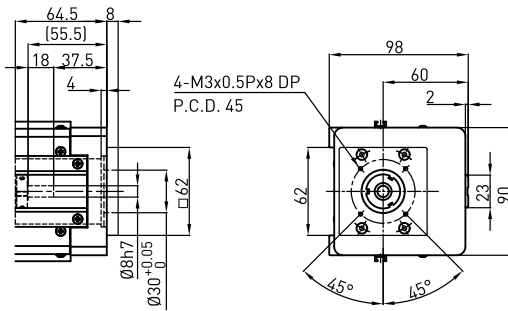

Motor Adaptor Flange F1

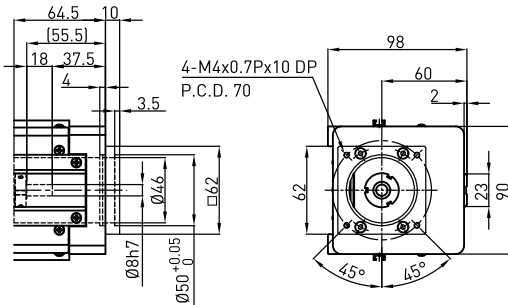

Motor Adaptor Flange F5

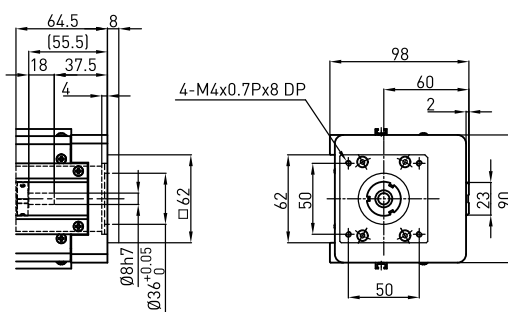

Motor Adaptor Flange F2

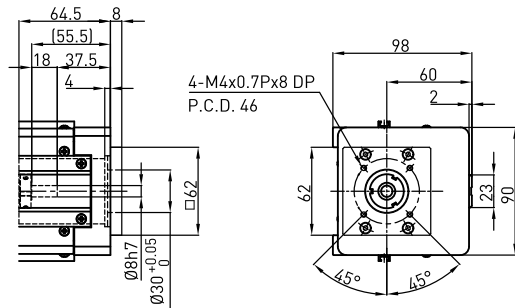

Motor Adaptor Flange F6

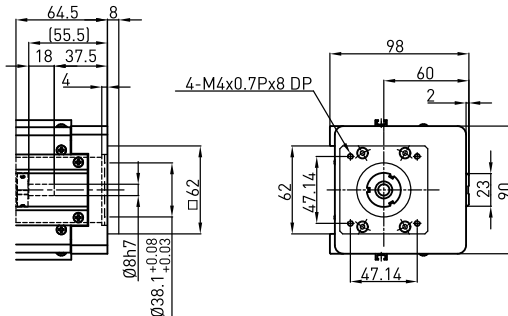

8.5 Motor Housing and Motor Adaptor Flange(KE Series)

HIWIN Mikrosystem Servo Motor

Motor Output	Motor	Flange Selection						Drive	Remarks
		KE30	KE40	KE50	KE65	KE70	KE90		
50W	FRLS052□□A4□	-	F2	F1	F1	F1	F3	D2T-0123-S-A□	220V
100W	FRLS102□□A4□	-	F2	F1	F1	F1	F3		220V
200W	FRLS202□□06□	-	-	-	-	-	F0	D2T-0423-S-B□	220V
400W	FRLS402□□06□	-	-	-	-	-	F0		220V
750W	FRMS752□□08□	-	-	-	-	-	-	D2T-1023-S-C□	220V

Mitsubishi Servo Motor

Motor Output	Motor	Flange Selection						Drive	Remarks
		KE30	KE40	KE50	KE65	KE70	KE90		
50W	HF-KP053	-	F1	F0	F0	F0	F2	MR-J3S-10A	220V
100W	HF-KP13	-	F1	F0	F0	F0	F2	MR-J3S-10A	220V
200W	HF-KP23	-	-	-	-	-	F0	MR-J3S-20A	220V
400W	HF-KP43	-	-	-	-	-	F0	MR-J3S-40A	220V
750W	HF-KP73	-	-	-	-	-	-	MR-J3S-70A	220V

Panasonic Servo Motor

Motor Output	Motor	Flange Selection						Drive	Remarks
		KE30	KE40	KE50	KE65	KE70	KE90		
50W	MSMD5AZP1	-	F2	F1	F1	F1	F3	MADDT1105	110V
50W	MSMD5AZP1	-	F2	F1	F1	F1	F3	MADDT1205	220V
100W	MSMD011P1	-	F2	F1	F1	F1	F3	MADDT1107	110V
100W	MSMD012P1	-	F2	F1	F1	F1	F3	MADDT1205	220V
200W	MSMD021P1	-	-	-	-	-	F1	MADDT2110	110V
200W	MSMD022P1	-	-	-	-	-	F1	MADDT1207	220V
400W	MSMD041P1	-	-	-	-	-	F1	MADDT3120	110V
400W	MSMD042P1	-	-	-	-	-	F1	MADDT2210	220V
750W	MSMD082S1	-	-	-	-	-	-	MADDT3520	220V

Yasukawa Servo Motor

Motor Output	Motor	Flange Selection						Drive	Remarks
		KE30	KE40	KE50	KE65	KE70	KE90		
50W	SGMAV-A5ADA61	-	F1	F0	F0	F0	F2	SGDV-R70A01A	with key
50W	SGMAV-A5ADA2C	-	F1	F0	F0	F0	F2	SGDV-R70A01A	no key
50W	SGMAV-A5ADA21	-	F1	F0	F0	F0	F2	SGDV-R70A01A	no key
100W	SGMAV-01ADA21	-	F1	F0	F0	F0	F2	SGDV-R90A01A	
200W	SGMAV-02ADA21	-	-	-	-	-	F0	SGDV-1R6A01A	
400W	SGMAV-04ADA21	-	-	-	-	-	F0	SGDV-2R8A01A	
750W	SGMAV-08ADA21	-	-	-	-	-	F1	SGDV-5R5A01A	

